



DCM COOLMASTER EVAPORATOR

AIR DEFROST

SUBMITTAL
DCM-869
 NOV. 1994
 SUPERCEDES
 DM-852



Description:

The DCM model unit coolers are designed for commercial and industrial walk-in coolers and industrial walk-in coolers and refrigerated warehouses. Time-tested for many years, these virtually maintenance-free unit coolers are built with Kramer reliability.

These units are suitable for maintaining room temperature of +35° and higher.

Features:

- Corrosion resistant casing, sturdy construction.
- Coils constructed of copper tubes and aluminum fins.
- Industrial evaporators with 8 FPI.
- Pitched drain pan for positive condensate drainage.
- Single phase motors have built-in overload protection.
- Dependable ratings based on laboratory tests.

PERFORMANCE DATA

MODEL	Capacity @ 10 T.D. (1)			CFM	Air Throw (4)	Motors		Total Fan Motor Amps (5)	
	Evaporator Temperature - °F					No.	H.P.	230-3-60	460-3-60
	+40° (2)	+30° (3)	+25° (3)						
DCM-560D	60900	56600	55975	8200	50	2	1/2	3.6	1.8
DCM-770D	83900	77900	77075	8000	50	2	1/2	3.6	1.8
DCM-1060D	115100	106900	15750	12400	100	2	3/4	7.0	3.5
DCM-1330D	144800	134500	133050	14200	100	2	3/4	7.0	3.5
DCM-1520D	165100	153400	151750	13800	100	2	3/4	7.0	3.5
DCM-1680D	182700	169800	167950	19200	100	3	3/4	10.5	5.3
DCM-1960D	213700	198600	196450	18500	100	3	3/4	10.5	5.3
DCM-2240D	243500	226300	223850	23900	100	4	3/4	14.0	7.0
DCM-2620D	284100	264700	261500	23100	100	4	3/4	14.0	7.0

8 FPI

1. Ratings based on R-22.
2. Non-frosting conditions.
3. Frosting conditions.
4. Unrestricted airflow.
5. Single phase motors are available, contact factory.

DIMENSIONAL DATA

8 FPI	MODEL	Dimensions (in)							Refrig. Charge (lbs) (1)	Approx. Ship Weight (lbs)	
		A	B	C	D	E	F	G			H
	DCM-560D	3-1/4	26	31-3/4	42-1/2	58	75	2-1/2	7-1/2	8	535
	DCM-770D	3-1/4	26	31-3/4	42-1/2	58	75	2-1/2	7-1/2	13	640
	DCM-1060D	3-7/8	26	32-3/8	42-1/2	94	111	2-1/2	7-1/2	16	950
	DCM-1330D	3-7/8	26	32-3/8	42-1/2	94	111	2-1/2	7-1/2	19	1055
	DCM-1520D	5-3/4	28	36-1/8	42-1/2	94	111	2-3/8	7-1/2	25	1225
	DCM-1680D	7-1/2	28-1/4	41-3/4	47-3/4	113-1/4	136	6	11-3/8	25	1580
	DCM-1960D	7-1/2	28-1/4	41-3/4	47-3/4	113-1/4	136	6	11-3/8	33	1800
	DCM-2240D	7-1/2	28-1/4	41-3/4	47-3/4	151-1/4	174	6	11-3/8	33	2650
	DCM-2620D	7-1/2	28-1/4	41-3/4	47-3/4	151-1/4	174	6	11-3/8	43	2800

CONNECTION DATA

8 FPI	MODEL	Connections (in) (6)			
		Suction O.D.	Liquid O.D.	Ext. Equal O.D.	Drain MPT
	DCM-560D	1-3/8	7/8	1/4	3/4
	DCM-770D	1-5/8	1-1/8	1/4	3/4
	DCM-1060D	1-5/8	1-1/8	1/4	3/4
	DCM-1330D	2-1/8	1-1/8	1/4	3/4
	DCM-1520D	2-1/8	1-1/8	1/4	3/4
	DCM-1680D	2-1/8	1-3/8	1/4	1
	DCM-1960D	2-1/8	1-3/8	1/4	1
	DCM-2240D	2-1/8	1-3/8	1/4	1
	DCM-2620D	(2) 2-1/8	(2) 1-1/8	(2) 1/4	1

For your convenience the diagram originally here is enlarged, and is now a separate page that can be found just after this page in the Adobe document.

6. Connection sizes are based on R-22, and may vary from catalog ratings when actual site operating conditions are provided at time of order.

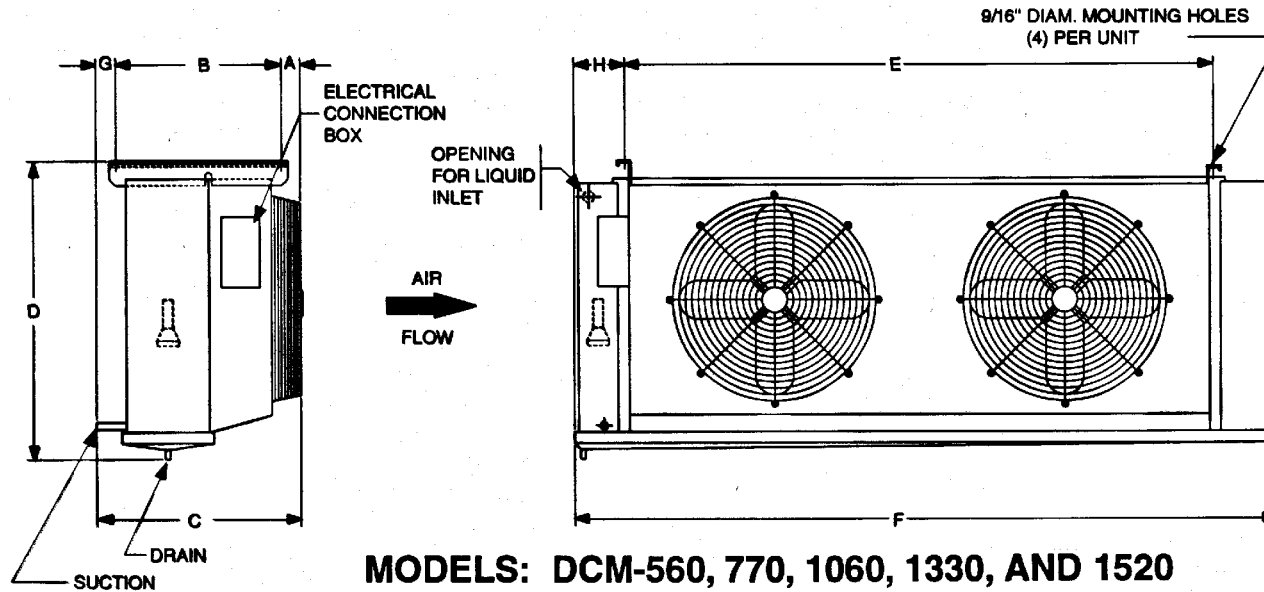

MODELS: DCM-560, 770, 1060, 1330, AND 1520

NOTES:- LEFT HAND COIL IS SHOWN, AND IS STANDARD. RIGHT HAND COIL MUST BE SPECIFIED WHEN ORDERING.
- ALL DIMENSIONS ARE IN INCHES.

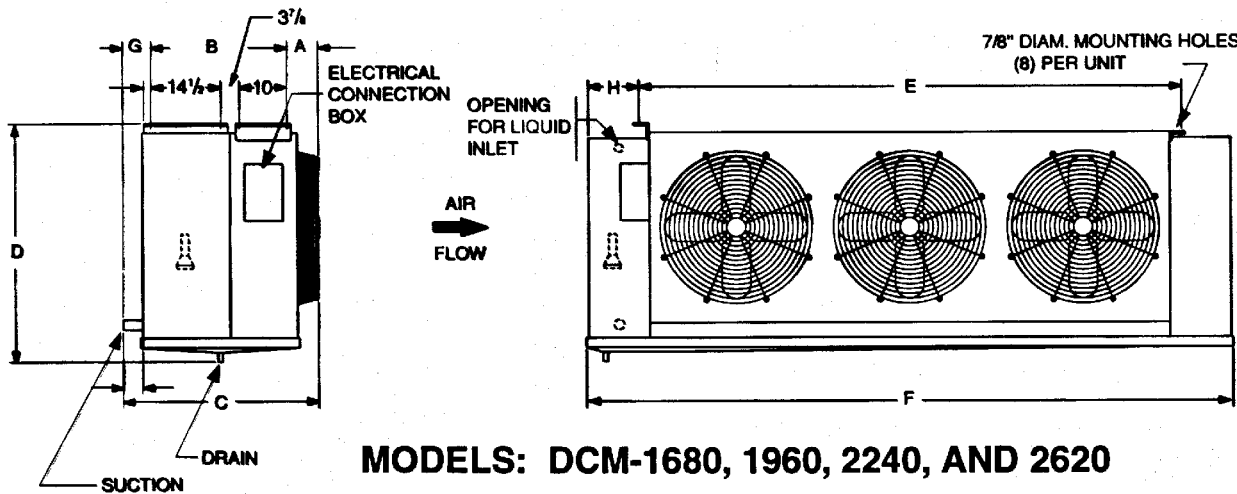

MODELS: DCM-1680, 1960, 2240, AND 2620

NOTES:- LEFT HAND COIL IS SHOWN, AND IS STANDARD. RIGHT HAND COIL MUST BE SPECIFIED WHEN ORDERING.
- ALL DIMENSIONS ARE IN INCHES.
- MODEL DCM-2620 HAS 2 SUCTION AND 2 LIQUID CONNECTIONS.

Specifications and dimensions are subject to change without notice.

KRAMER 14230 Lochridge Boulevard / Covington, GA / 30014

Phone: 770-788-5800 Fax: 770-788-5820

www.kramerusa.net